

NOTE: paint all steel
refer to dwg. STD-C27.2
for tread and stringer section



STAIRWELLS
TYPICAL DETAIL AT BASE OF STAIR

date: January 2002
drawn by: R.C.

drawing no: STD - A25.1
elementary

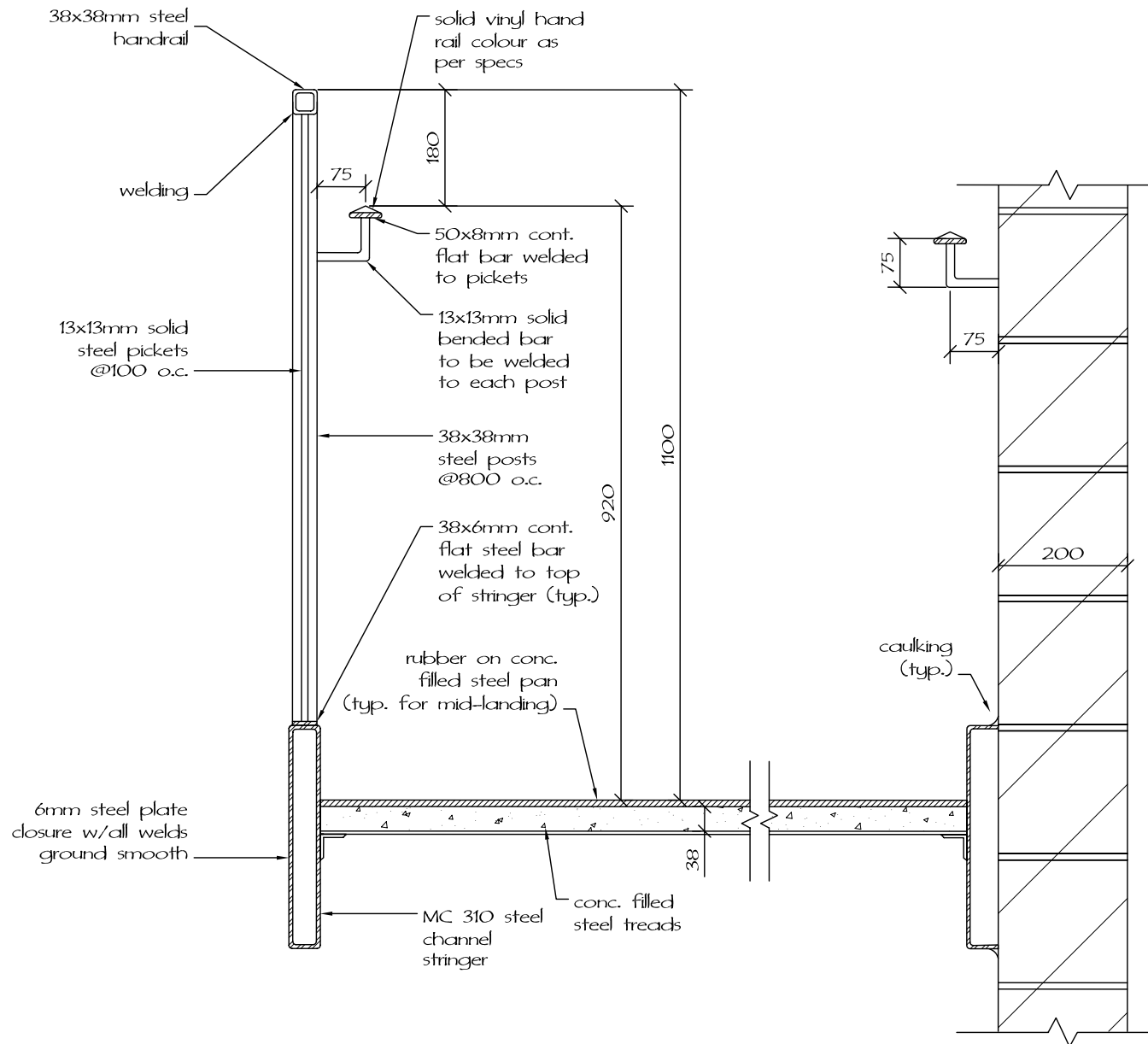

STAIRWELLS
TREAD & STRINGER SECTION

date: March 2002
drawn by: R.C.

drawing no: STD - A25.2
elementary

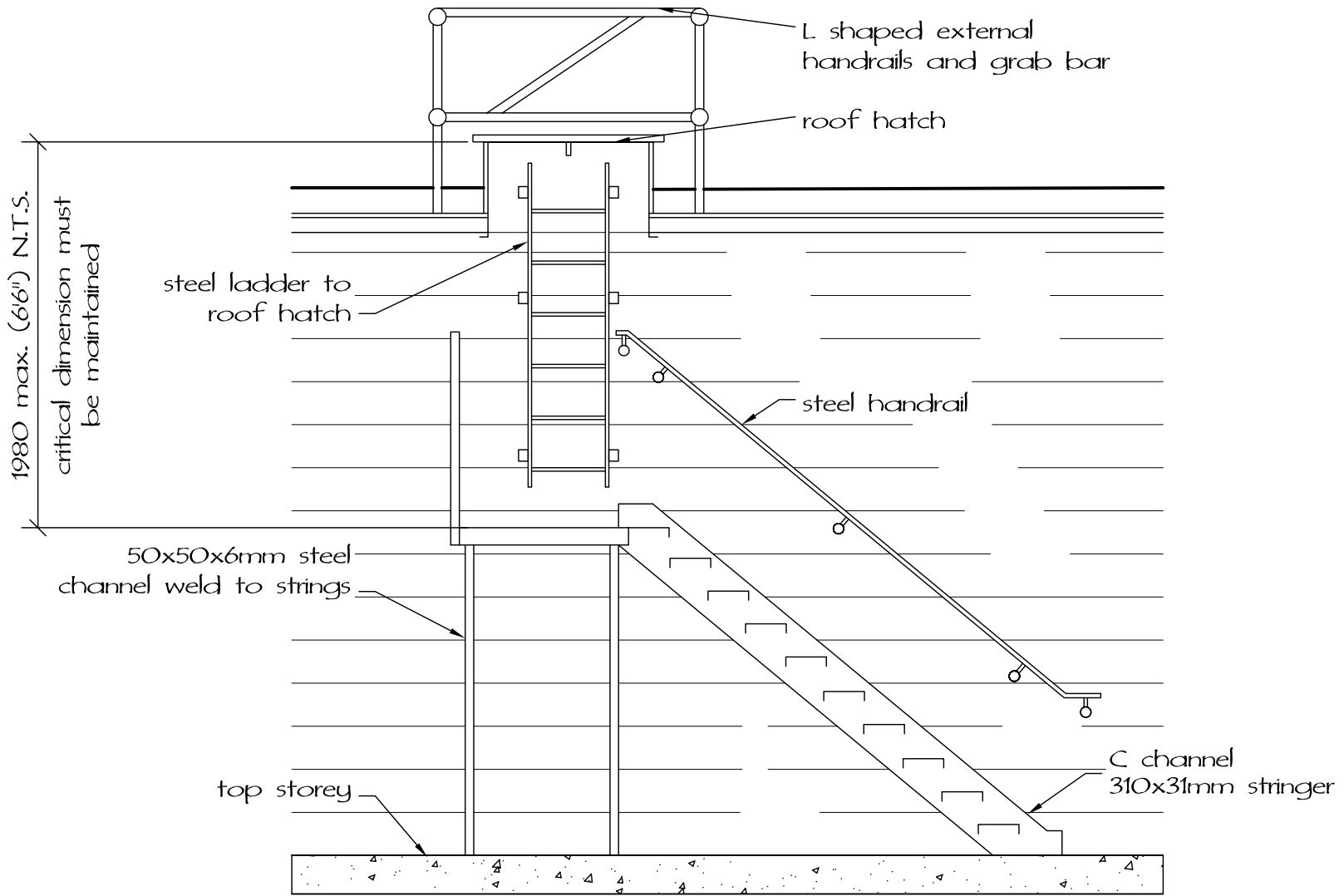

STAIRWELLS
STAIRS AT MECHANICAL ROOM

date: March 2002
drawn by: R.C.

drawing no: STD - A25.3
elementary

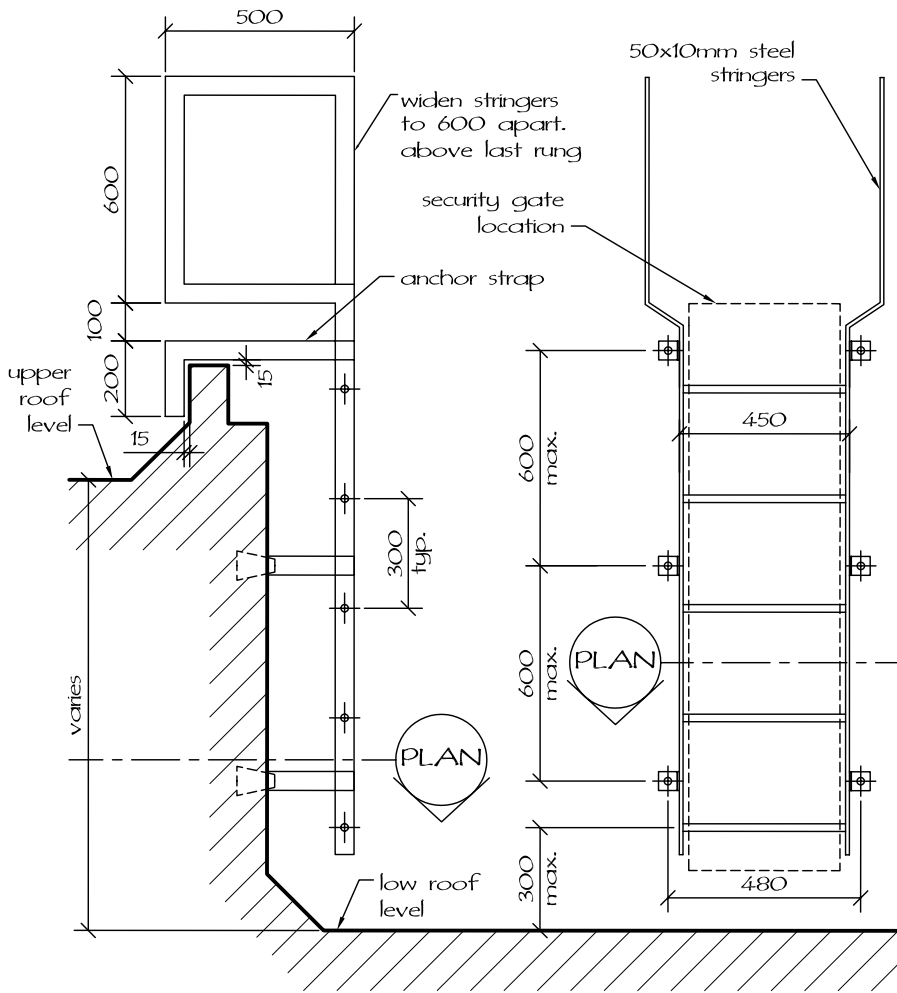

SECTION

ELEVATION

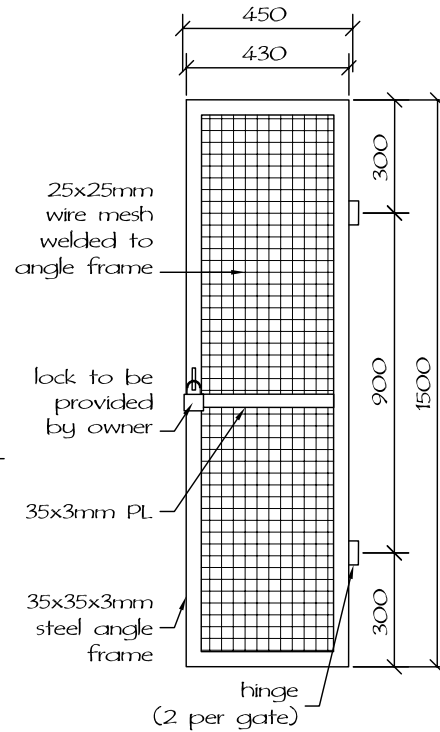

SECURITY GATE

ELEVATION

LOCK DETAIL

AXONOMETRY

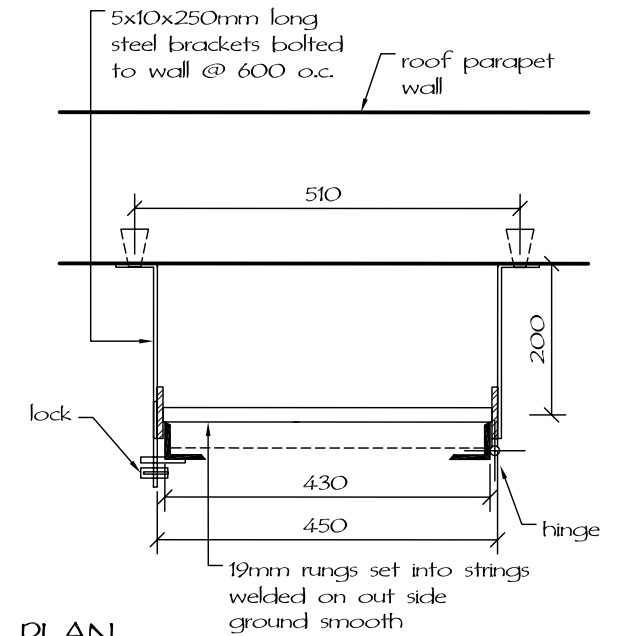
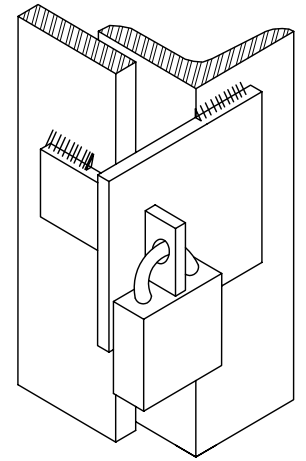

PLAN



STAIRWELLS
STEEL LADDER AT ROOF

date: April 2002
drawn by: R.C.

drawing no: STD - A25.4
elementary